

VOLTAGE BASED CONTROL OF INDUCTION MOTOR USING ADVANCED VOICE RECOGNITION & COMMAND SYSTEM

Mayur B. Deokate¹ & G. H. Agrawal²

¹Research Scholar, Department of Electrical Engineering, KDK College of Engineering, Nagpur, India

²Professor, Department of Electrical Engineering, KDK College of Engineering, Nagpur, India

Received: 03 Jun 2021

Accepted: 07 Jun 2021

Published: 21 Jun 2021

ABSTRACT

It is difficult to work in dangerous environment in numerous of the businesses. Human can survive as it were certain sum of temperature, weight etc. To work in environment over a run will cause risk to human life. Thus the framework is planned to diminish hazard of human life as well is more precise and computerized to alter itself to commanded parameters. The framework has highlight of voice command-based control of IM Drive for mechanical purposes through strategy of voltage variety. Moreover, it has essential highlights of drive assurance based on warm and over current security of drives. Gadget is having closed input circle framework based on tachometer speed sensor to alter speed precisely and keep up it indeed in the event that stack shifts. The voice acknowledgment gadget utilized is Alexa by Amazon and it communicates to custom planned drive control through Wi-Fi utilizing Hub MCU

KEYWORDS: 3 Phase Induction Motor, Voice Controlled Induction Motor, Voice Recognition Module, Microcontroller, Speed Control, AC Motor, Alexa Echo Device, Voice Reorganization And Command System, Variable Frequency And Variable Voltage Drive VFD

INTRODUCTION

As we all know the numbers of accidents are more in Electrical Industries. While people take proper precautions but sometimes an industrial accident claimed the lives of employing operators. As per analysis of electrical accidents the cases are reduced up to 40% now but still the safety measures of every worker, employer and operator is concerning. Automation in electrical industry is more now a days and it helps reduce the need for human intervention. Automation and control systems enable safe and efficient operation of industrial plants by minimizing risks.

But to create an alternative to work in hazardous environment voice control was developed. Voice control is used mainly to reduce the manual operation. Here, voice communication plays a major part in this project. We are utilizing voice communication totally different areas for different purposes. Engine speed can be shifted by diverse speed control plans at rotor side and stator side of the engine. In stator side we have voltage control, recurrence control. Voice technique we are going to control speed of IM using voltage variation. Speed control of AC/DC motor is used for various applications. The designed system utilizes device named Alexa Echo Dot by Company AMAZON in AI Devices Section this device will be used to recognize voice. The main unit utilizes a NODE

MCU which receives the digital data via Wi-Fi communication (no need of Internet, hotspot technology). On-board present AT-Mega 328p Microcontroller will process digital data and send signal (PWM in nature) to the servo

actuator to rotate the dimmer shaft as per speed requirement. The PWM values are generated with control circuits that have timer features 8bit or more. So it can be analogized that the value of 0 means stop and the maximum value of 255 means full deflection. The system is designed to control speed of induction motors in various steps as well as it provides thermal and over current protection to IM. A tachometer feedback system will be attached to Drive for accurate and automatic speed control.

MAIN COMPONENTS OF PROJECT

- Alexa Echo Dot.
- Node MCU.
- Servo motor.
- Variable Voltage Frequency Drive.
- 3Phase Induction Motor.
- Tachometer feedback.

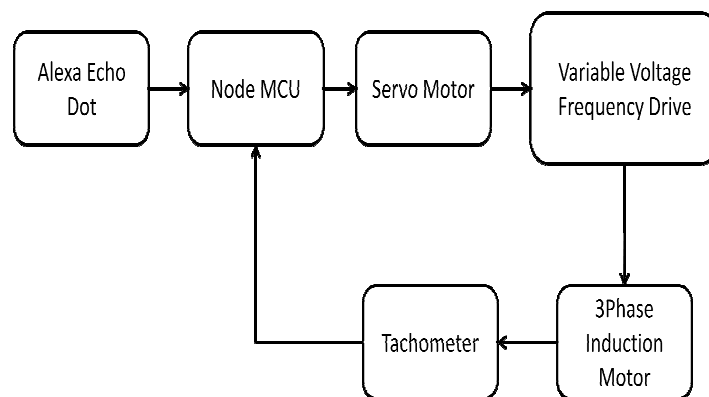

Figure 1: Main Components of Project.

BLOCK DIAGRAM

Start with the 12 volt 10 amp SMPS power supply which we are going to use we supply Voltage to the Electronic circuit turn we can see there is a Alexa echo dot device which we are going to use for voice recognition and the process data will be process by the Alexa and signal send to the Node MCU then NODE MCU is going to process the received signal of the voice command it is then going to the process based on the program set in the micro controller the program will identified there required rpm of IM now it will send to the actuating servo motor. The servo motor will actuate the signal in term of degree and will rotate the variable resistor as per the degree wise and which is going to give feedback to the VFD. Now as we know the VFD is a drive which varies speed of induction motor and control the speed of Induction motor using variation voltage and frequency required and VFD will send suitable voltage and frequency required for a suitable rpm to the 3 phase Induction motor. In this system for a suitable RPM to the 3 phase to be supplied by contactor based on relay module, relay Module and Contactor Which is controlled by protection unit For a protection Purpose for over current protection thermal protection which we have going to give.

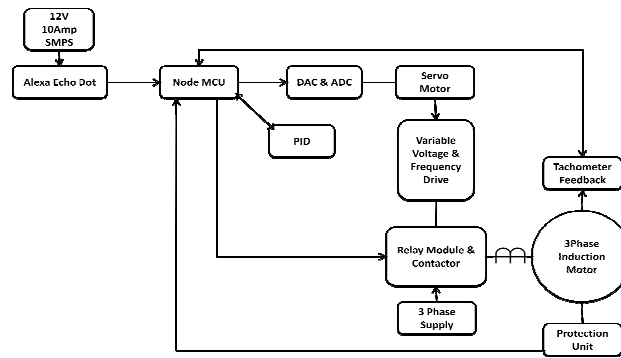

Figure 2: Block Diagram.

PIN DIAGRAM OF NODE MCU

The Node MCU ESP8266MOD Wi-Fi module is used. Node MCU is a Node Micro Controller unit is an open-source software and hardware development environment built around an inexpensive system-on-a-chip (SoC). Design based on the architecture of 30 pin layout. It has 4 power pins: VIN Pin and three 3.3V Pins, GND: Ground Pin, ADC channel: Embedded with 10-bit precision SAR ADC, UART Pins, SPI Pins, SDIO Pins, PWM Pins, CONTROL Pins: EN, RST, WAKE. This Chip contains crucial elements of the computer that are CPU Ram Networking (Wi-Fi) and even modern operating system and SDK.

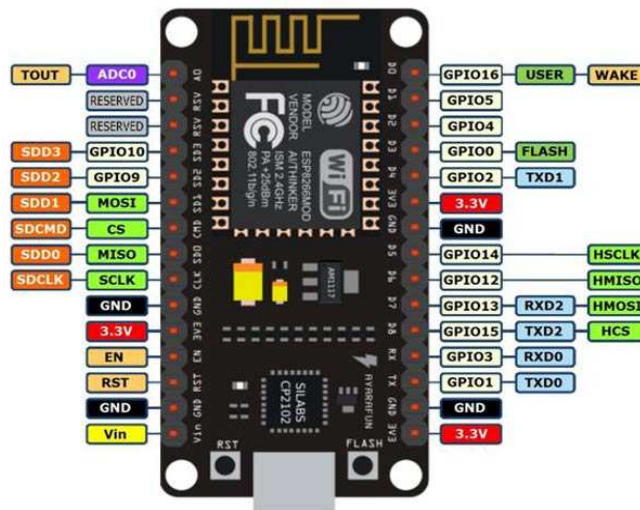

Figure 3: Design of Experiment.

DESIGN OF EXPERIMENT

The system is using wireless communication digital command send through Wi-Fi to the node MCU. The command received by the microcontroller and actuated by the servo it adjusts the speed in 0 to 360degrees of the shaft. The servo assembly which will control the Dimmer stat and microcontroller accurately adjust voltage and feedback speed it will adjust the speed.

The protection parameters are very accurate when the load exceeds the safety parameter, Dimmerstat gets tripped and motor gets isolated and the current turned off.

Again the implanted thermister close to the winding gives feedback of winding temperature and core temperature when it exceeds the temp of insulation it sends tripping signal.

Working of Alexa is much accurate as compared with other products in a market also this setup can also control up to 50 motors if wanted. Safety and security criterion is more in this case also comparative to other products it's cheaper and efficient to work.

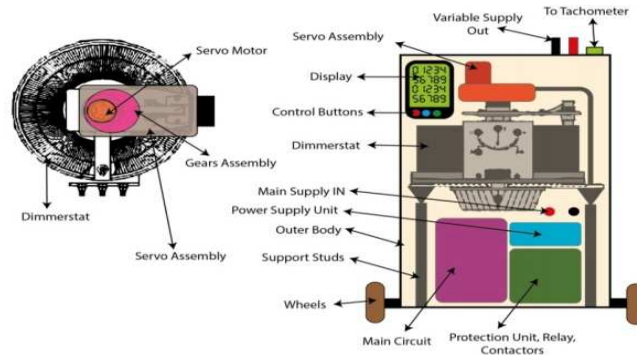

Figure 4: Design of Experiment.

ADVANTAGES

- High Accuracy and Resolution.
- More Safe and Secure.
- More numbers of motors can be connected.
- Cheap in cost.
- Easily accessible.

CONCLUSIONS

Recent developments in the technology are making the life easier. This project work explains the design and construction of Voice controllable motor. This voice command technique will improve the performance of the motor.

REFERENCES

1. "A DC Motor Speed Control Using The LPC-Anfis Speech Recognition System", Paper No. 978-602-50431-6/2017, 15th International Conference QIR: INTL. Symp. Elect. And Com. Engg., Muhammad Akil, Ingrid Nurtanio, Rhiza Samsoe'oad Sadjad, Department Of Elect. Engg., Hasanuddin University, Makassar, Department Of Mechatronic Engg., Bosowa Polytechnic, MAKASSAR. (IEEE)
2. "Speed Control of DC Motor Using Voice Commands", Paper No. 978-1-5090- 5/16/2016, 2016 International Conference On Computation Of Power, Energy Information & Communication (ICCPEIC), T. Mathurri Sai, S. Keerthi Kumar, UG Scholar, Sathyabama University, PG Student, CIE Depart., St. Joseph's College of Engg., Chennai, India.(IEEE)
3. "Voice Recognition Based Intelligent Wheelchair & GPS Tracking System", Paper No. 978-1-5386-9111-3/19, 2019 International Conference On Electrical, Computer & Communication Engg, (ECCE), 7-9 February, 2019, Nasir Aktar, Israt Jahan, Bijoya Lala, Department Of Electrical & Electronics Engg, University of Chittagong, Chittagong-4331, Bangladesh. (IEEE)

4. “Design And Development Of Voice / Joystick Operated Microcontroller Based Intelligent Motorised Wheelchair”, Paper No. 0-7803-5739-6/99, H. R. Singh, Abdul Mobin, Sanjeev Kumar, Sundeep Chauhan* And S. S. Agrawal, Central Electronics Engg, Research Institute, Csic Complex, Hillside Road, New Delhi – 110 012, India.(IEEE)
5. “Design And Development Of Voice Controllable Wheelchair”, Paper No. 978-7281-7016- 9/20, 2020 8th International Conference On Reliability, Infocom Technologies And Optimization (Trends And Future Directions) (ICRITO) Amity University, Noida, India, June 4-5, 2020, Polash Dutta, Abhishek Kumar, Aditi Singh, Kartik Saha, Bitupon Hazarika, Ansuma Narzary, Tonmoy Sharma, Mechanical Engg. Department, Tezpur University, Tezpur Assam, India. (Ieee)

BIOGRAPHIES



Name: Mayur B. Deokate

Email: Mayurbdeokate.ee@kdkce.edu.in

Department: Electrical Engineering



Name: Dr. G. H. Agrawal

Email: ghagrwal66@yahoo.com

Department: Professor of Electrical Engineering Department

